

Technical data

Supply Voltage: 220-240 V~, 50 Hz

Bulb Type: 78520 / 78522 / 78524--8.5W LED Module, 3000K This product contains a light source of energy efficiency class **E**.
78521 / 78523 / 78525--8.5W LED Module, 4000K This product contains a light source of energy efficiency class **D**.

  Non-replaceable light source

 Non-replaceable control gear



Conformity with all relevant UKCA Directive requirements.

Conformity with all relevant EC Directive requirements.



The power supply is Double Insulated and does not require connection to an Earth circuit.



Waste electrical products should not be disposed of with household waste. Please recycle where facilities exist. Check with your Local Authority or local store for recycling advice.



This product is suitable for dimming.



This product fire rated to 30, 60 & 90 minutes.

Care and Safety

We recommend cleaning with a soft dry cloth. Do not use solvents or abrasive cleaners as these could damage the finish.

For your safety, always switch off the power supply before cleaning.

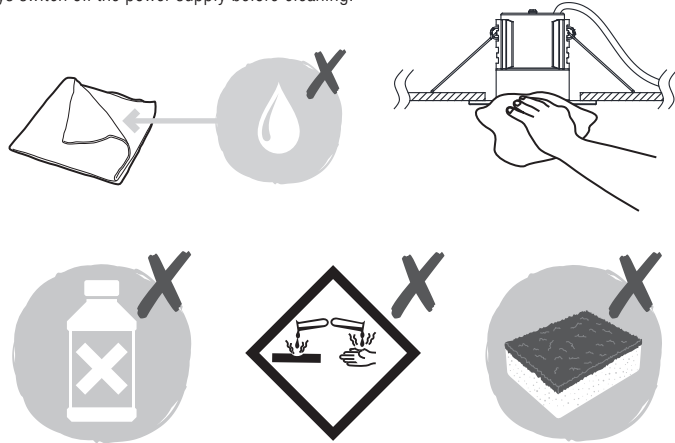

For further information, please visit <https://www.lighting-info.co.uk/78520>

V4 28/10/2022
UK Manufacturer: BH17 7BY
EU Manufacturer: Brilliant AG,
Brillantstrasse 1, D-27442 Gnarrenburg

saxby
lighting

Instruction manual

ShieldECO 800 Tilt

78520, 78521, 78522, 78523, 78524, 78525



www.saxbylighting.com

saxby
lighting

Thank you for purchasing this light fitting. Please read the instructions carefully before use to ensure safe and satisfactory operation of this product. Please retain these instructions for future reference.

Warning

 This light fitting is double insulated and does not require connection to an earth circuit.

Please read these instructions carefully before commencing any work

This unit must be fitted by a competent and qualified electrician.

Install in accordance with the IEE Wiring regulations and current Building Regulations.

Check the pack and make sure you have all the parts listed.

To prevent electrocution switch off at the mains supply before installing or maintaining this fitting. Ensure other persons cannot restore the electrical supply without your knowledge. If you are in any doubt, please consult a qualified electrician.

This light fitting should be connected to a fused circuit.

If replacing an existing fitting, make a careful note of the connections.

This product complies with Building Regulations Part B and is suitable for use in 30, 60 & 90 minute fire rated ceilings.

This system contains non-replaceable parts and cannot be serviced. If damage occurs the part should be scrapped.

Waste electrical products should not be disposed of with household waste. Please recycle where facilities exist. Check with your local authority or retailer for recycling advice.

Layout

Plan the desired layout of these fittings carefully, ensuring the cables will reach the distances between the transformer and each light fitting.

Avoid locating any cables in positions that would cause a hazard. Position cables and junction boxes (not supplied) away from areas where they may be at risk from being cut, trapped or damaged.

The mains supply cable must have a minimum cross section area of 1.0mm².

Cables must be protected using suitable conduit or plastic trunking.

The unit must be located a minimum distance of 50mm from a joist.

The distance between units must be 0.5m minimum.

This product must be mounted out of arms reach.

This product is suitable for covering with insulation 270mm.

Installation

Existing fittings must be completely removed before installation of a new product. Before removing the existing fitting, carefully note the position of each set of wires.

The ceiling surface must be flat and smooth to ensure a good fit.

Note that the switch is turned off before installation.

Ensure that the screws and cable entry points are sealed to maintain the IP rating of the product.

- After deciding the layout of the light fittings ensure that the cables are long enough to connect to desired positions.
- Cut a mounting hole 70mm diameter in the ceiling taking care not to foul any pipes, mains cables or joists beneath the surface. It is always recommended to cut the hole slightly smaller than the size specified, and then file the hole until the recessed unit fits snugly.
- Ensure a minimum ceiling void depth of 60mm is available.
- Pull the mains wire through the hole and open the cover of connect box to wire as detailed wiring.
- Push the spring clips upwards and fit into the ceiling hole, then push the unit up until firmly in position, ensuring that no cables are trapped. Ensure that the product is sitting properly in the hole.
- Replace circuit breaker and switch on. Your light is now ready for use.

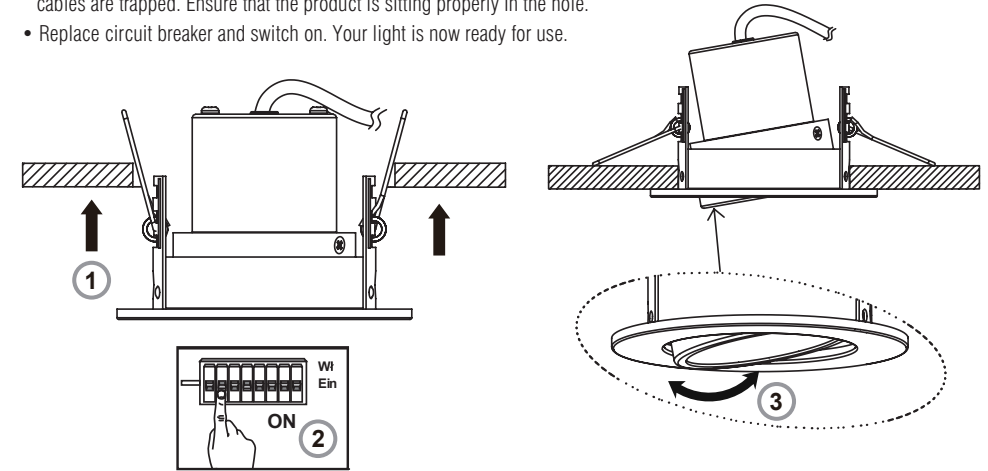

Wiring

Unclip the cover from the quick fit connection case. Having correctly identified the wiring from your existing light fitting, pull the mains wire through the hole and connect to the connection block inside the quick fit connection case in the following way. No tools are necessary.

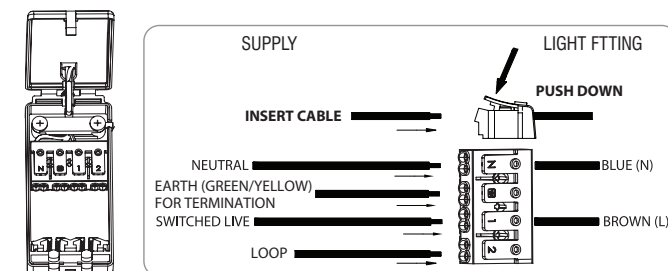

Check that...

You have correctly identified the wires.
The connections are tight.
No loose strands have been left out of the connection block.
The cover on the connection box has been replaced.