

MICROWAVE DETECTOR

90978

Sensor Adjustment

- Turn the TIME knob anti-clockwise on the minimum (10s). Turn the LUX knob clockwise on the maximum (+).
- When you switch on the power, the light will be on at once. And 10sec ± 3sec later the light will be off automatically. Then if the sensor receives induction signal again, it can work normally.
- When the sensor receives the second induction signals within the first induction, it will restart to time from the moment.
- Turn LUX knob anti-clockwise on the minimum (-). If the ambient light is less than 10LUX (darkness), the inductor load could work when it receives induction signal.

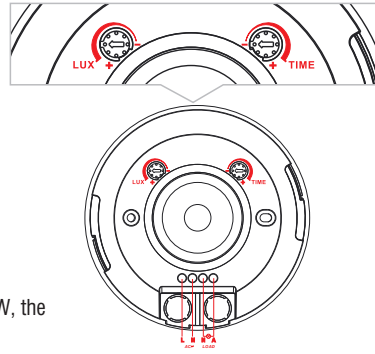

Note: when testing in daylight, please turn LUX knob to + position, otherwise the sensor lamp could not work! If the lamp is more than 60W, the distance between lamp and sensor should be 60cm at least.

Technical data

Supply Voltage: 220-240V~

Detection Range: 360°

Power Frequency: 50Hz

Detection Distance: Max. 8m (radius)

HF System: 5.8GHz CW radar, ISM band

Power Consumption: approx 0.9W

Ambient Light: <10-2000LUX (adjustable)

Transmission Power: <10mW

Time-Delay: Min.10sec±3sec

Installing Height: 1.5~4m

Max.15min±3min

Detection Motion Speed: 0.6~1.5m/s

Rated Load: 2000W

1000W



Conformity with all relevant UKCA Directive requirements.

Conformity with all relevant EC Directive requirements.



The power supply is Double Insulated and does not require connection to an Earth circuit.



Waste electrical products should not be disposed of with household waste. Please recycle where facilities exist. Check with your Local Authority or local store for recycling advice.



This product is not suitable for dimming.



This product is rated at IP20.

Care and Safety

We recommend cleaning with a soft dry cloth. Do not use solvents or abrasive cleaners as these could damage the finish. For your safety, always switch off the power supply before changing lightbulbs, or cleaning.



Thank you for purchasing this light fitting. Please read the instructions carefully before use to ensure safe and satisfactory operation of this product. Please retain these instructions for future reference.

Warning

 This product is double insulated and does not require connection to an Earth circuit.

Please read these instructions carefully before commencing any work.

This unit must be fitted by a competent and qualified electrician.

Install in accordance with the IEE Wiring regulations and current Building Regulations.

Check the pack and make sure you have all the parts listed.

To prevent electrocution switch off at the mains supply before installing or maintaining this fitting. Ensure other persons cannot restore the electrical supply without your knowledge.

If you are in any doubt, please consult a qualified electrician.

If replacing an existing fitting, make a careful note of the connections.

This unit should be connected to a fused circuit.

This unit is only suitable for indoor use.

Waste electrical products should not be disposed of with household waste. Please recycle where facilities exist. Check with your local authority or retailer for recycling advice.

Layout

This product is designed for optimum performance when mounted in ceiling 1.5-4m above the ground.

Avoid pointing at or positioning close to heat sources such as flues or heat extraction units, which may cause false triggering.

Avoid pointing at bright lights as unit will not function when you set Lux control Level to dark.

Avoid locating near electromagnetic fields.

The mains supply cable must have a minimum cross section area of 1.0mm².

Cables must be protected using suitable conduit or plastic trunking.

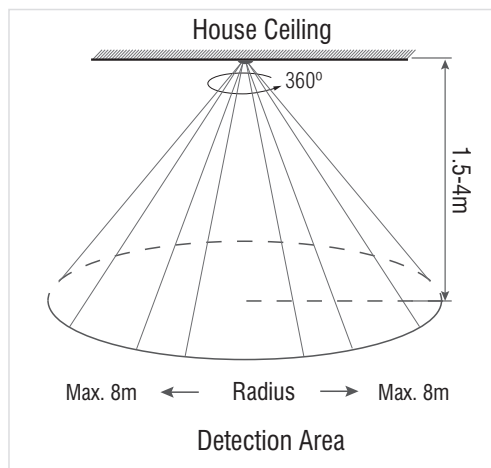

Installation

Existing fittings must be completely removed before installation of a new product. Before removing the existing fitting, carefully note the position of each set of wires.

Note that the switch is turned off before installation.

Ensure that the screws and cable entry points are sealed to maintain the IP rating of the product.

After deciding the layout of the light fittings ensure that the cables are long enough to connect to desired positions.

- Fix the bottom on the selected position with the inflated screw through the screw holes at the side of the sensor.
- Connecting the power and the load to sensor as per the connection-wire sketch diagram.
- The wires come in and out from the side or bottom.
- After finishing installing, turn on the power and then test it.
- Wire as detailed below.

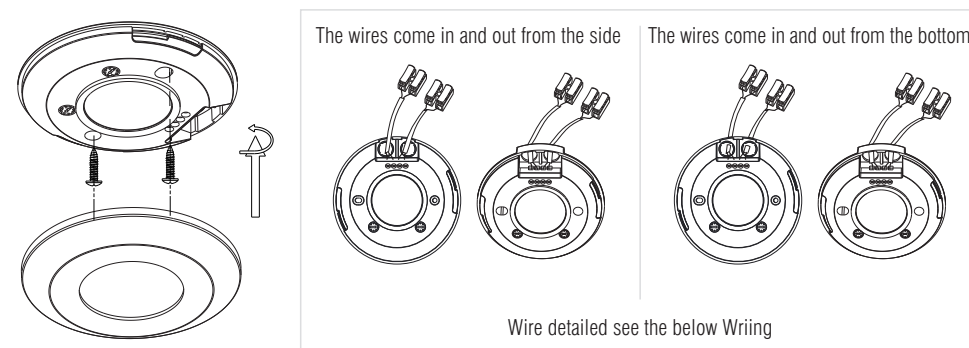

Wiring

This product is double insulated and must not be earthed. If there are any incoming earth cables, they must be joined together and well insulated with good quality insulation tape. This is to ensure earth continuity throughout your property.

Having correctly identified the wiring from your existing light fitting and connect to the connection block inside the product in the following way:

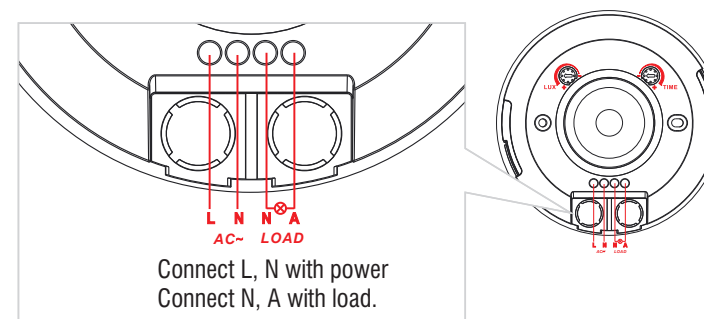

Check that...

You have correctly identified the wires

No loose strands have been left out of the connection block

The connections are tight

The cable clamp is fitted over the wires.