

Additional instructions

Instruction for RularPlus/RularPro IP20

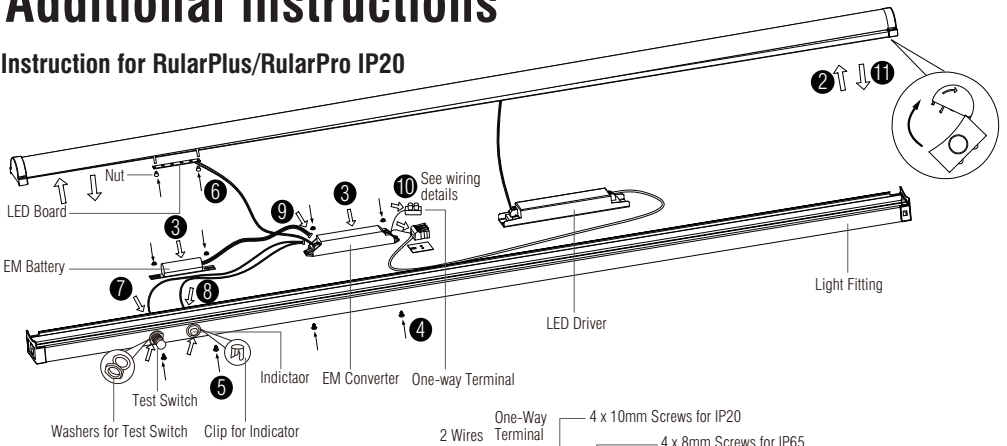

1. Ready all the EM kit accessories: EM converter, EM battery, LED board, test switch, indicator, one-way terminal, screws, nut, 2 wires.
2. Press down the metal frame of rear base slightly then rotate both ends of the product in the direction of the arrow to open the diffuser cover.
3. Locate the EM converter and EM battery to the holes, ensure the EM converter output is close to the battery.
4. Secure the EM converter to the light fitting with 2 screws by screwdriver.
5. Secure the EM battery to the light fitting with 2 screws by screwdriver.
6. Secure the LED board to the PCB board with 2 white nuts, keep the out-wire is on backplate.
7. Pull the test switch through the hole then using 2 washers to secure.
8. Insert the clip into the hole for indicator, then insert the indicator through the clip to secure it.
9. Insert the wire of LED board, EM battery, test switch, indicator in the corresponding position on EM converter.

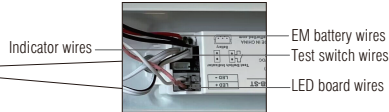
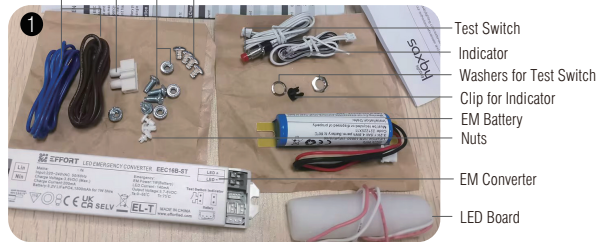

10. Wire as per the wiring diagram below:

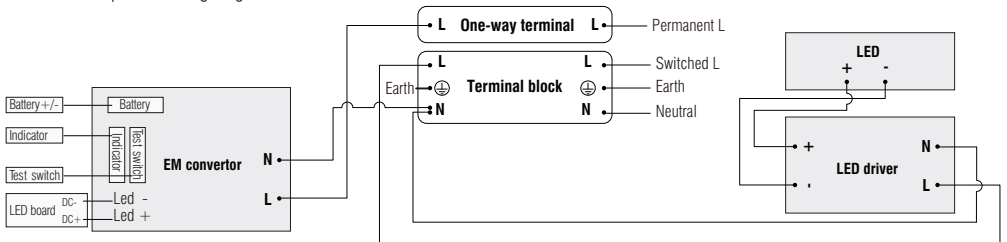

11. Re-close diffuser cover into the place.

Instruction for LED Anti-Corrosive batten IP65

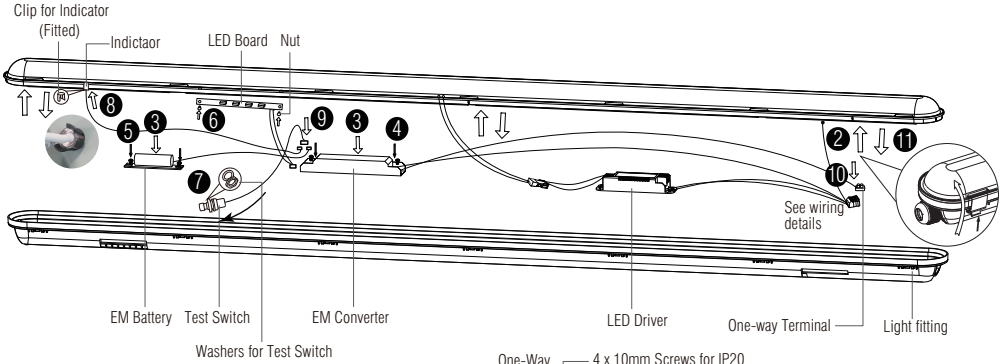

1. Ready all the EM kit accessories: EM converter, EM battery, LED board, test switch, indicator, one-way terminal, screws, nut, 2 wires.
2. Open the diffuser cover by unfastening securing clips.
3. Locate the EM converter and EM battery to the holes, ensure the EM converter output is close to the battery.
4. Secure the EM converter to the light fitting with 2 screws by screwdriver.
5. Secure the EM battery to the light fitting with 2 screws by screwdriver.
6. Secure the LED board to the PCB board with 2 white nuts, keep the out-wire is on backplate.
7. Screw the 2 washers into the test switch and place it on the appropriate position of rear housing.
8. Insert the indicator into the clip to secure it.
9. Insert the wires of LED board, EM battery, test switch, indicator in the corresponding position on EM converter.

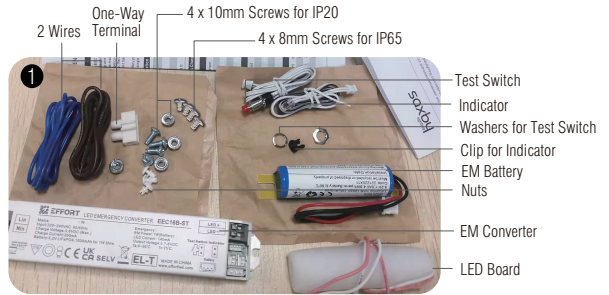

10. Wire as per the wiring diagram below:

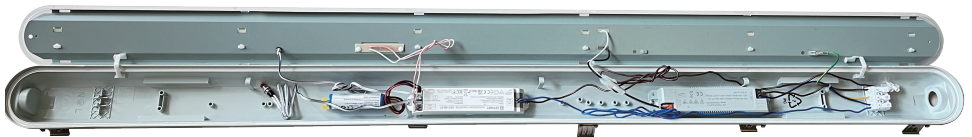
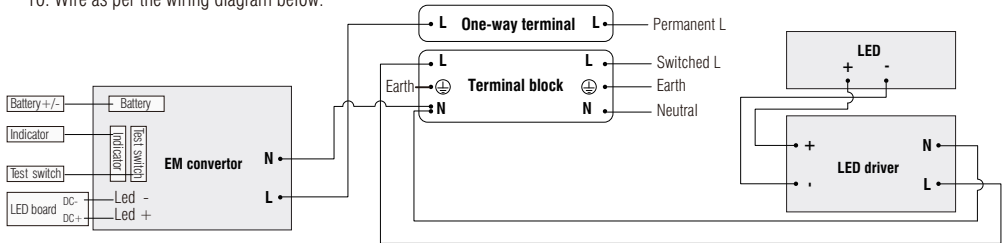

11. Re-close diffuser cover by clipping it into place.