

BATTEN EM KIT MANUAL & SELF TEST 2-IN-1

107137



Relevant standard

IEC 61347-1
IEC 61347-2-7
EN 55015
EN 61547
EN 61000-3-2
EN 61000-3-3
EN 62493
AS/NZS 60598-2-22
AS2293.3

Warranty

- Warranty 5 years. (Emergency driver and battery)
- Except for the following circumstances:
1) Improper installation or operation.
2) Misuse.
3) Abuse.
4) Unauthorized or improper repair alteration.
5) Accident or negligence in use, storage, transportation.
6) Any natural acts.

Instructions for Disposal (End-of-Life Management): This product contains a battery which must be disposed of separately from household waste at the end of its life. To protect the environment and human health, please ensure proper disposal of this battery and the product.

Information for Recyclers: To ensure safe and efficient recycling, the battery should be removed by trained professionals in accordance with local regulations and industry best practices for battery recycling.

We are committed to responsible sourcing of raw materials used in our products, including batteries. We adhere to robust due diligence policies to prevent and mitigate social and environmental risks throughout our supply chain, in accordance with Regulation (EU) 2023/1542.

Dimensions

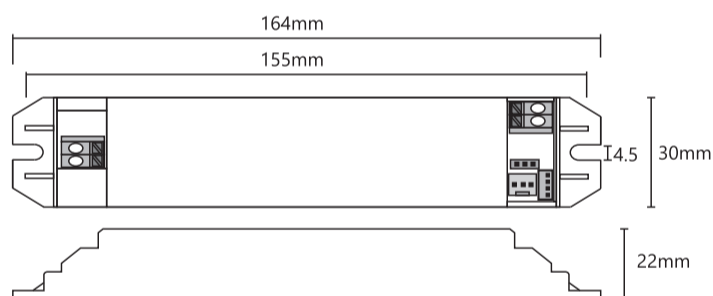

Self-test

The emergency kits carry out self-tests automatically to ensure its functionality. The self-test includes 3 types of tests:

Initial test

- As soon as mains supply is connected, the emergency kit will carry out a 3-seconds functional test automatically.
- In case of a failure, the LED will turn permanent red. Otherwise, the charge mode will start.

Functional test

- Refers to charging, discharging and the functioning of load.
- Carry out for 10 seconds automatically every 30 calendar days.

Duration test

- Refers to the test of batteries capacity.
- Carry out every 180 calendar days.

Reset mode

Rest mode can be initiated during emergency mode by pressing test switch longer than 3 seconds.

The rest mode will be exited automatically after reconnect AC mains.

Reset method(choose either of below):

1. AC power off, press and hold test button more than 5s;
2. AC power off and unplug battery, wait 5s and plug battery.

* During initial installation, the indicator light might be showing red and fitting working properly, please keep it charging for few hours, then reset, the indicator should change to green.

Please note

If mains supply is off during self-test period, emergency conversion module would terminate self-test immediately and go into emergency mode.

Self-test is under the regulation of EN 62034.

Thank you for purchasing this product. Please read the instruction carefully before use to ensure safe and satisfactory operation of this product. Please retain these instruction for future reference.

Applications

- Use in dry environment.
- LiFePO4 battery pack.
- For use on a wide range of LED fittings to convert them from standard to emergency fitting.
- LED fitting would be maintained emergency LED fitting if standard (main powered) driver, emergency lighting kit and battery are all retained in the circuit. LED fitting would be non-maintained emergency LED fitting if only emergency lighting kit. And battery are retained in the circuit.
- Additional Relay that can control standard LED driver.
- Deep discharge protection.
- Connector between emergency kit and battery has the function of polarity reversal protection.
- Ambient range ta 0...45 C
- IP20 protection, relies on end-product enclosure for protection against accidental contact live parts.
- Not intended for use in luminaries for high-risk task area lighting.
- Can turn off self test mode by dial switch.

Ordering data

E.M Power	Duration	Battery Pack
DC2.5-3.5V 1W constant power	3 Hours	LiFePO4 3.2V 1.6Ah 5.12Wh

Technical data

Item	Data
Rated input	220-240VAC,50/60Hz, 20mA, 2Wmax
Output voltage range	DC 2.5-3.5V
Max output current	400mA
Output power	1W max
Battery cells voltage /capacity	LiFePO4 3.2V 1.6Ah 5.12Wh
Recharge current	130mA
Recharge time	24hours
Discharge time	180 minutes
Max. casing temperature tc	80 °C

Wiring diagram

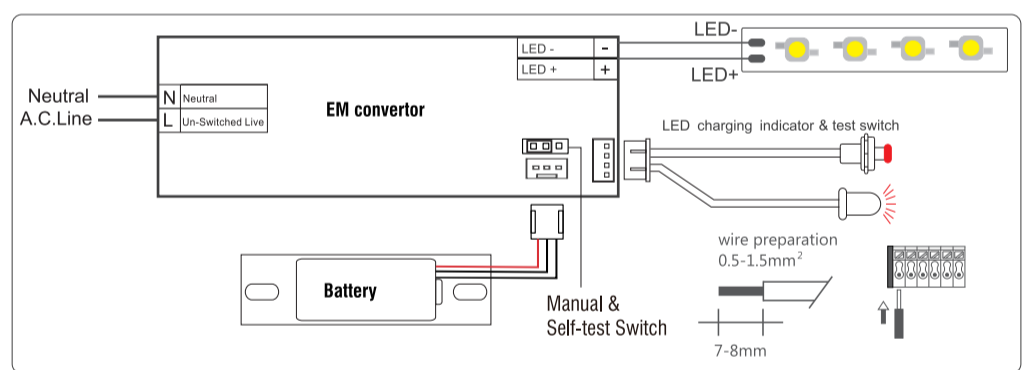

Explanation of LED indicator

	Color	LED indication	Status	Comment
	Green	Slow flashing green (3 sec on, 1 sec off)	Charging Mode	AC mode
	Green	Permanent green	Fully Charged	AC mode
	Green	Fast flashing green (0.1 sec on, 0.1 sec off)	Function test underway	
	Green	Slow flashing green (1 sec on, 1 sec off)	Duration test underway	
	Red	Permanent red	Load failure	Open circuit / Short circuit Led failure (emergency mode)
	Red	Slow flashing red (1 sec on, 1 sec off)	Battery failure	Battery failed the duration test or function test / No battery
		Green and red off	DC mode	Battery operation (emergency mode)

Test switch

The test button is an open switch, if you press it, it connects, and then you release it, it cuts off automatically.

When you are doing the daily maintenance, if you press the test button, the emergency driver goes into emergency mode, if you release the button, the emergency driver will go back to normal mode.

Instruction for RularPlus/RularPro IP20

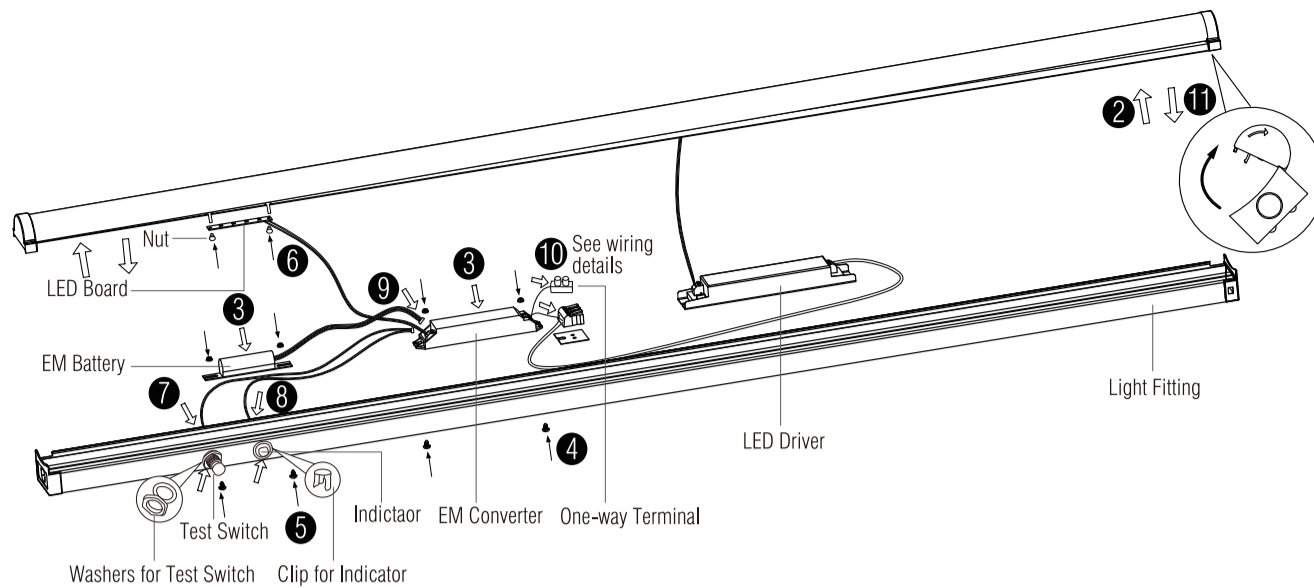
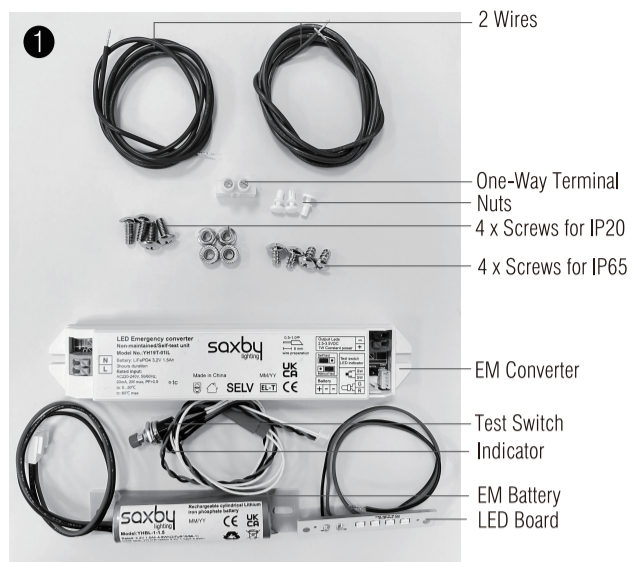

1. Ready all the EM kit accessories: EM converter, EM battery, LED board, test switch, indicator, one-way terminal, screws, nuts, 2 wires.
2. Press down the metal frame of rear base slightly then rotate both ends of the product in the direction of the arrow to open the diffuser cover.
3. Locate the EM converter and EM battery to the holes, ensure the EM converter output is close to the battery.
4. Secure the EM converter to the light fitting with 2 screws by screwdriver.
5. Secure the EM battery to the light fitting with 2 screws by screwdriver.

6. Secure the LED board to the PCB board with 2 white nuts, keep the out-wire is on backplate.
7. Remove the 2 washers from the Test Switch, pull the test switch through the hole then using 2 washers to secure fitting in the.
8. Removed the clip from the Indicator, then insert the clip into the hole from outside the fitting, then insert the indicator from inside the fitting then through the clip to secure it.
9. Insert the wire of LED board, EM battery, test switch and indicator in the corresponding position on EM converter.
10. Wire as per the wiring diagram.
11. Re-close diffuser cover into the place.

Wiring

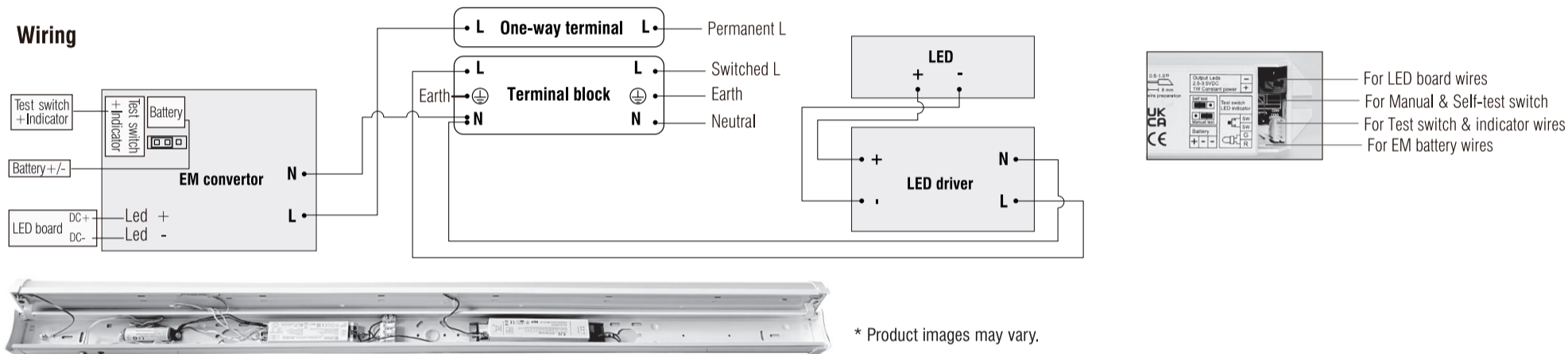

* Product images may vary.

Instruction for Rular Base

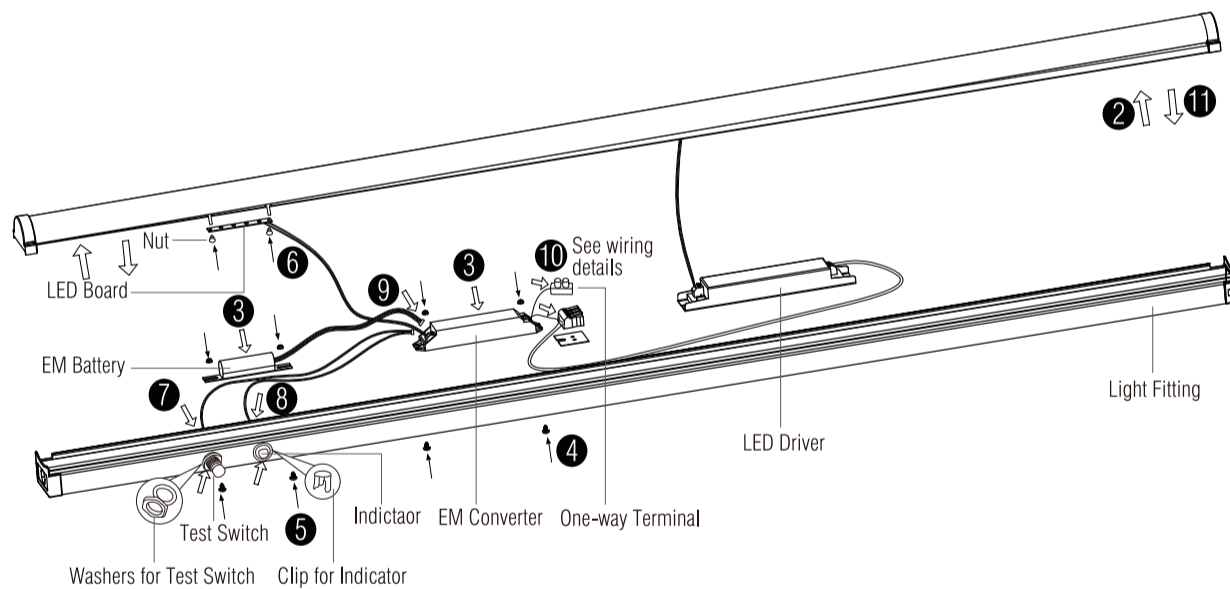
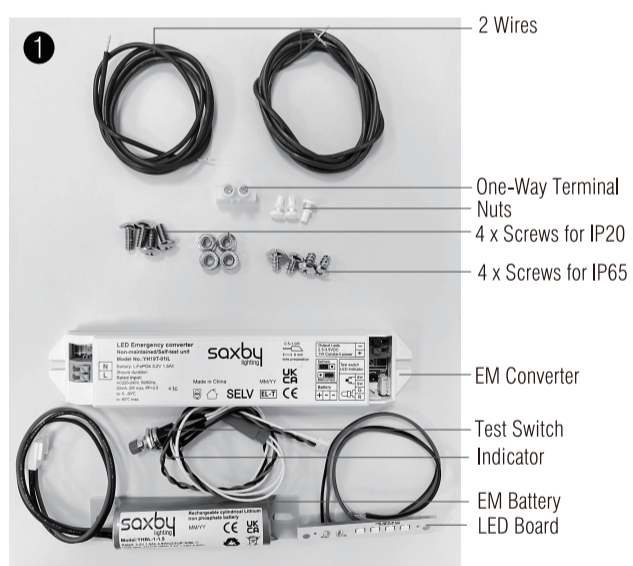

1. Ready all the EM kit accessories: EM converter, EM battery, LED board, test switch, indicator, one-way terminal, screws, nuts, 2 wires.
2. Separate the rear base and the diffuser cover in the direction.
3. Locate the EM converter and EM battery to the holes, ensure the EM converter output is close to the battery.
4. Secure the EM converter to the light fitting with 2 screws by screwdriver.
5. Secure the EM battery to the light fitting with 2 screws by screwdriver.

6. Secure the LED board to the PCB board with 2 white nuts, keep the out-wire is on backplate.
7. Remove the 2 washers from the Test Switch, pull the test switch through the hole then using 2 washers to secure fitting in the.
8. Removed the clip from the Indicator, then insert the clip into the hole from outside the fitting, then insert the indicator from inside the fitting then through the clip to secure it.
9. Insert the wire of LED board, EM battery, test switch and indicator in the corresponding position on EM converter.
10. Wire as per the wiring diagram.
11. Re-close diffuser cover into the place.

Wiring

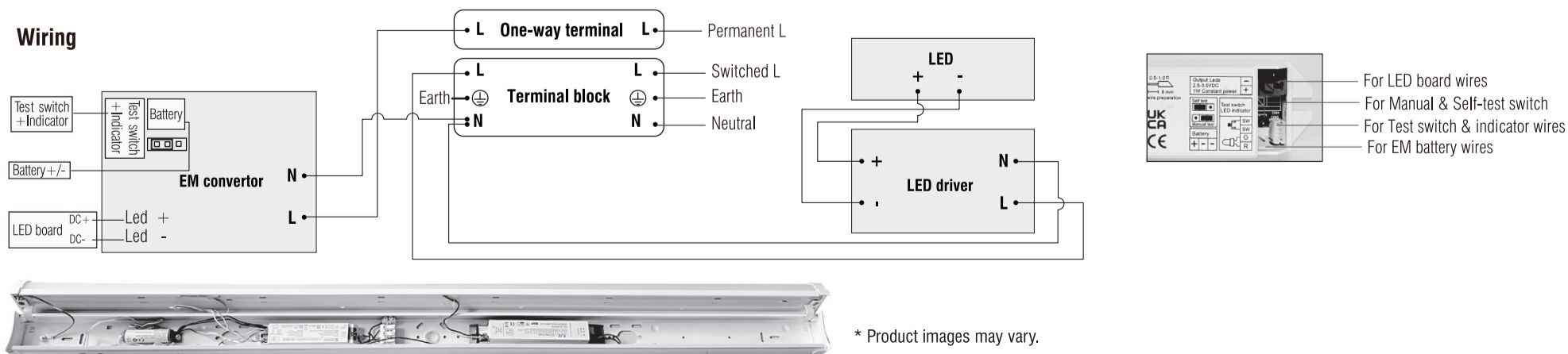

* Product images may vary.